

SYSTEM 85

35 - 50 C85

RESIDENTIAL INTEGRATION

3KW KIT FOR TILE ROOF

35x50C roof-integrated mounting system - 3kW kit for tile roof
 Système (35x50C) intégré individuel Kit 3kW Toiture tuile
 KIT 3kW Integración individual 35x50C con marco
 KIT 3kW integrierte Unterkonstruktion für Wohnhäuser - Ziegel

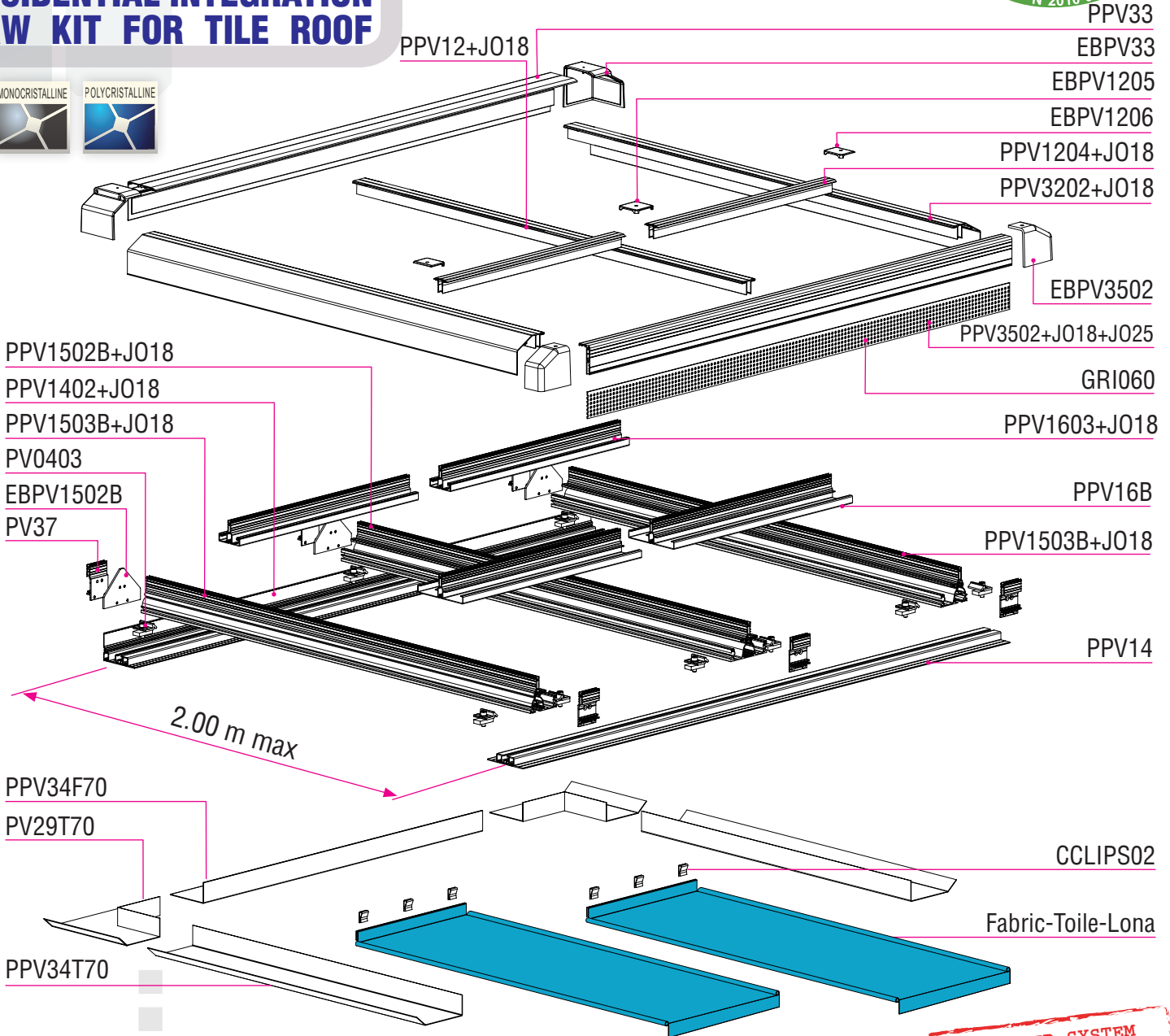

PATENTED SYSTEM
 SYSTÈME BREVETÉ
 SISTEMA PATENTADO
 N° P200930027

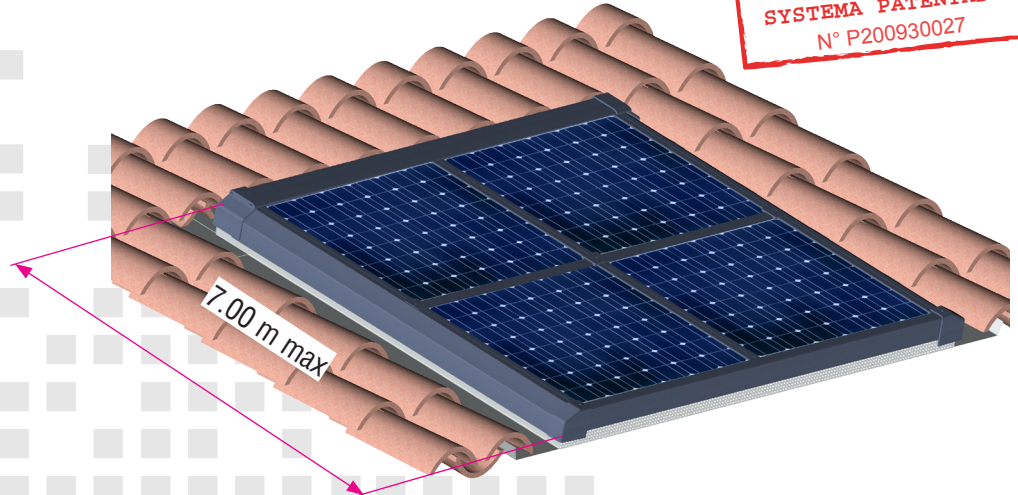
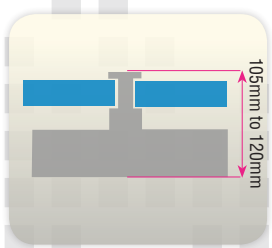

3kW KIT 85 Residential integration



35-50C Integrated system 3kW kit for tile roof

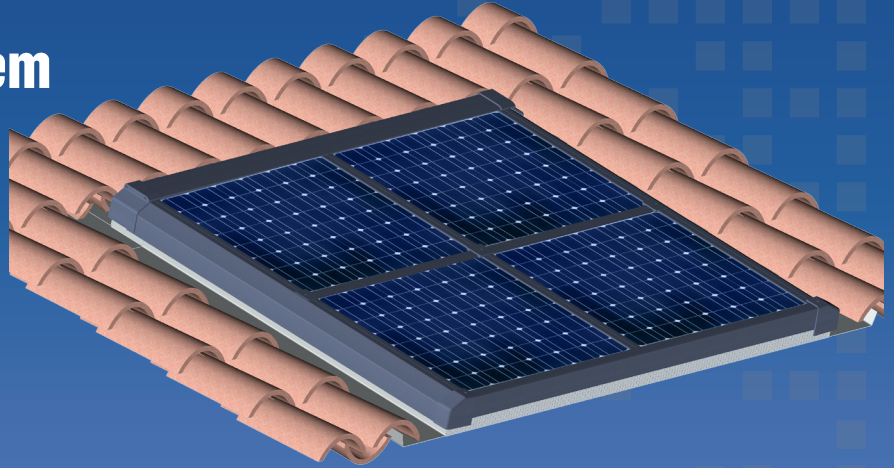

+ ADVANTAGES

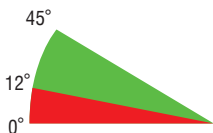

Tilt angle

- Quick installation
- Tile roof integration
- Aesthetic and design

For 35mm to 50mm thick panels



LANDSCAPE INSTALLATION
RECOMMENDED



FOR FRAMED PANELS

Structure components:

Aluminium profiles
Aluminium foundry pieces (AS13)
A2 stainless steel fastenings RAL 7016 +
EPDM washer and joint

Finish:

- mill finish
- powder coated with PTFE
textured finish RAL 7016

Intermodule rafter

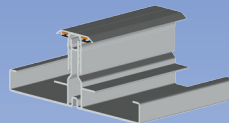

Support rail

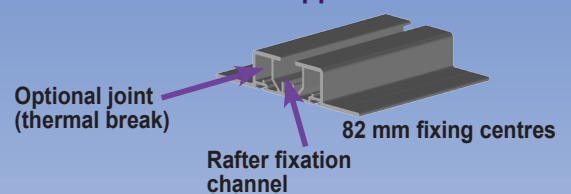

Connectors

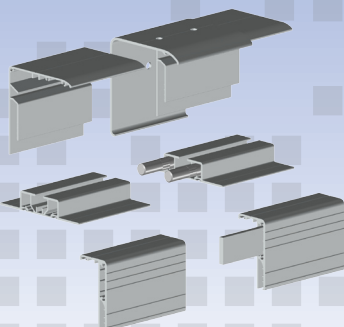

Side rafter

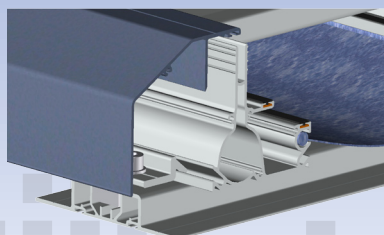

Central rafter

